

DESIGN NOTES

LTC1436-PLL Low Noise Switching Regulator Helps Control EMI

Design Note 141

John Seago

Electromagnetic interference (EMI) is a potential problem for the circuit designer. Switching regulators can cause EMI in many products. Linear Technology has developed new techniques like spread-spectrum modulation, phase-locked synchronization and Adaptive Power™ mode that can reduce the amount of unwanted interference.

New IC Solves Old Problems

The LTC®1436-PLL is a constant-frequency, current mode, synchronous step-down switching regulator that controls external N-channel MOSFETs for very efficient power conversion. It also features Adaptive Power mode, which provides constant frequency switching with good efficiency at light load currents. Figure 1a shows the audio frequencies generated by the 5V output of the circuit in Figure 2, while supplying 3mA of load current (0.1% of full load) using a cycle-skipping mode of operation. This mode may cause many cycles to be skipped between bursts of energy to the output capacitor. These energy bursts intrude into the audio band at sufficiently low output currents. Figure 1b shows that audio frequency noise is completely eliminated by the Adaptive Power mode under the same conditions.

Traditionally, efficiency is sacrificed to accomplish the audio frequency response shown in Figure 1b. Large synchronous MOSFETs are used to force continuous inductor current at the switching frequency, regardless of the load. The associated gate charge losses and losses caused

by relatively large inductor ripple current result in very poor efficiency at light loads. The Adaptive Power mode uses only the small (SOT-23) MOSFET, Q3 and D2 in a conventional buck mode to allow constant frequency, discontinuous inductor current operation, which greatly decreases power loss. The gate-to-source capacitance of the small MOSFET is significantly less than either of the two large MOSFETs. Depending on component selection, there can be a 50-to-1 difference in gate-to-source capacitance between Q3 and Q1/Q2, so that Q3 requires only 2% of the gate drive power (loss) of Q1/Q2. This provides a substantial increase in efficiency at light loads.

New Feature Provides New EMI Control

In addition to audio frequency suppression, the LTC1436-PLL has three additional RF EMI control mechanisms:

1) The LTC1436-PLL allows switching frequency modulation to spread the spectrum of switching noise. Through frequency modulation, peak energy is decreased and spread over a wide range of frequencies as shown in Figure 3. The normal 190kHz switching frequency and its harmonics are shown by the black trace. The colored trace shows the result of modulating the phase-locked loop lowpass filter (PLL LPF) pin with a 100Hz sawtooth waveform. Switching frequency energy is reduced by over 20dB when modulated; second and third harmonics are attenuated even more in this example. Figure 4 shows the spectrum out to

LT, LTC and LT are registered trademarks of Linear Technology Corporation. Adaptive Power is a trademark of Linear Technology Corporation.

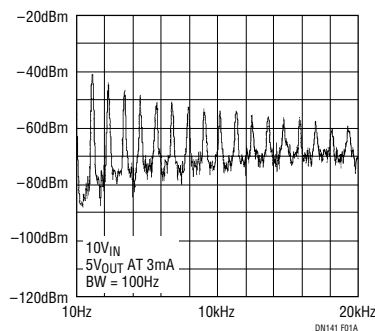

Figure 1a. Audio Frequency Generation in Cycle-Skipping Mode

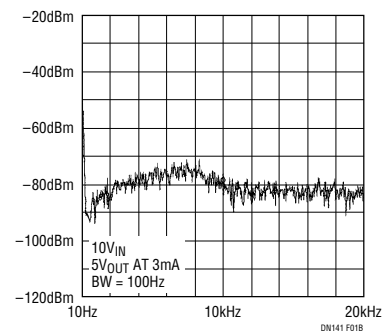

Figure 1b. Audio Frequency Amplitude with Adaptive Power Mode Operation

100MHz resulting from PLL LPF modulation under the same conditions as in Figure 3.

2) The switching frequency can be programmed anywhere from 50kHz to 400kHz by selecting the appropriate value of oscillator capacitor. This places harmonics away from sensitive frequencies like 455kHz.

3) The switching frequency can be phase-locked to an external system clock so that harmonics and sidebands of the switching frequency are common with those generated by the system. This phase lock can be maintained over a $\pm 30\%$ frequency range around f_0 .

Additional Features

The LTC1436-PLL provides a power-on reset timer function that flags an out-of-range output voltage condition, along with an auxiliary regulator that controls an external PNP transistor for an additional low noise, linear regulated output. The LTC1437 has all the features of the LTC1436-PLL plus an internal comparator with reference that can be used to detect a low-battery condition or provide other useful functions. The basic LTC1436 trades the phase-locked loop function for the additional comparator in the LTC1437.

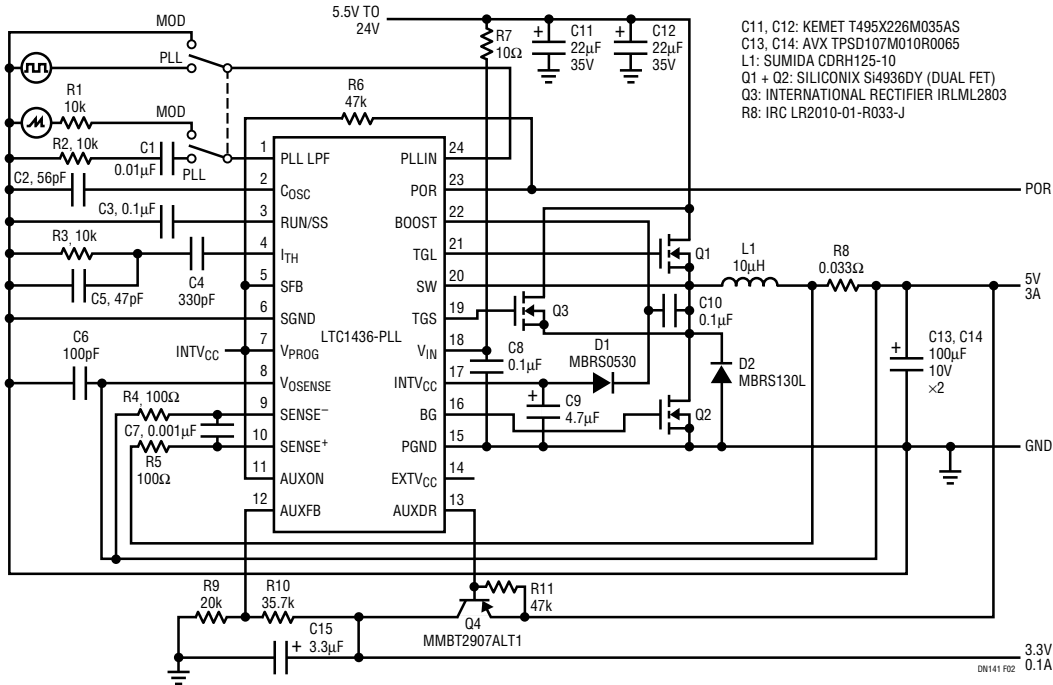

Figure 2. Two Output LTC1436-PLL Circuit

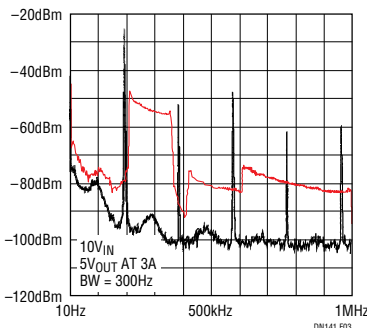

Figure 3. Before and After Frequency Spreading

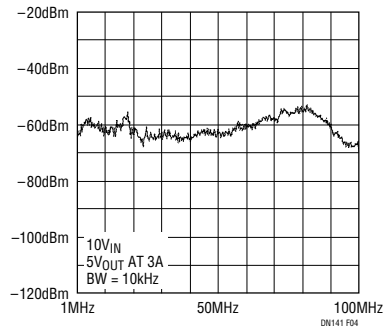

Figure 4. High Frequency Response with Frequency Spreading

For literature on our Switching Regulators, call **1-800-4-LINEAR**. For applications help, call (408) 432-1900, Ext. 2361